



CENTRIFUGAL JUICER    MASTICATING JUICER    VEGETABLE & FRUIT PULPER    HOT BEVERAGE VENDING MACHINES

# Jas ENTERPRISES

AN ISO 9001:2008 CERTIFIED COMPANY

**60, SHREENATHJI ESTATE, PANNA ESTATE ROAD, RAKHIAL, AHMEDABAD, GUJARAT - 380025, INDIA**  
**TELEPHONE: +(91)-(79)-22745454 FAX: +(91)-(79)-22745062 GSM: +(91)-9427417384- 9426068680**  
**URL: <http://www.jasenterprise.com/>**  
**E mail: [info@jasenterprise.com](mailto:info@jasenterprise.com) & [jasparvan1990@gmail.com](mailto:jasparvan1990@gmail.com)**

DUE TO CONTINUOUS IMPROVEMENTS, WE RESERVE THE RIGHTS TO ALTER AND/OR AMEND DIMENSIONS DESIGN WITHOUT PRIOR NOTICE.



## VIBRO SCREEN

JAS Vibro Screens are designed on the principle of gyratory motion generated by double eccentric weight mounted on two ends of the shaft of vertically mounted specially designed vibratory motor. The screening assembly consisting of one or more set of Deck/screens is mounted on a set of angularly located springs, effectively isolating the base from vibrating assembly.

The double weight moving with the shafts and located at relative angular position produces three dimensional vibrations which in turn cause the material falling on the screen mesh move at a specific speed in straight to spiral direction giving controlled and effective screening.

Due to the adjust ability of weight and the relative angle between them it is possible to make the material move on the screen in desired path to achieve the desired retention time



for effective screening before the material gets discharged from the outlet spout. During this process the particles smaller than the mesh aperture fall through the mesh and the oversize material gets discharged from the outlet spout. This process is repeated on the next mesh in case of multi deck screening.

## Features

**Greater Capacity** - Gyro screen gives greater capacity per meter square of screening area and oversize material is discharged with relatively less percentage of fines when compared to other screening machines.

**Longer Screen Life** - Screen cloth is held in uniform tension on specially designed mesh frames. The tight screening surfaces vibrates rigidly without flexing of wires, greatly reducing screen wear and increasing screen life.

## Operating Principle of Gyro Screen

The material to be screened is fed on to the center of top screen. The under-size material passes rapidly through the screen during its travel to the periphery. The over size material is continuously discharged through a tangential outlet. Vibro Sifters are equipped to handle multiple screens one on top of the other with feed trays in between to give several precise sized fractions in a single screening operation. Special designs with up to seven screens are also available for grading.

The top weight on the motor shaft rotates in a plane close to the center of mass of the assembly. Rotation of the top eccentric weights create vibration in the horizontal plane which causes the material to move across the screen cloth to the periphery. Increasing the top eccentric mass increases the horizontal throw causing oversize material to discharge at a faster rate.

The bottom eccentric weights rotate below the center of the vibrating mass creating tilt on the screens giving vibration in vertical and tangential planes. Increasing the vertical component of motion promotes turn over of material on the screen surface helping maximum quantity of under-size material to pass through the screen. The effective vertical motion helps in minimizing blinding of screen.

The tangential component of motion is controlled by the angle of lead given to bottom weights with relation to top weights. Variation in lead angle controls the spiral pattern of material travel over the screen cloth. Speed and flow pattern of material travel over the screen cloth can be set by the operator for maximum through-put and screening efficiency. Typical material travel patterns generated at various lead angles are shown below.

## Adjustment of top & bottom weights in accordance with the following diagrams

{Example of screen patterns for average materials}



0° Lead average material will be through straight



30° Lead average material will being to spiral



60° Lead average material will give maximum screening pattern



90° Lead oversize material does not discharge

## GYRO SCREEN

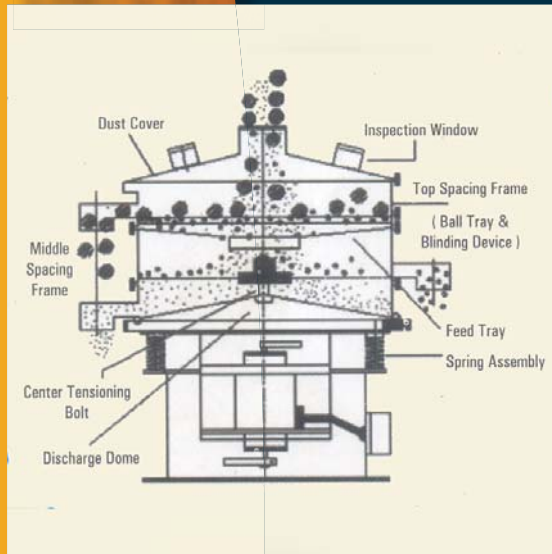

### Application of Vibro Screen (Gyro screen)

The Techno Vibro screens are use for a wide range of application e.g. food industries, dehydrated food, spices, flour, ago industries, guar gum, isabgul, Seeds, wheat, sesame, whole spices, nuts castor, soya, Ceramics industries, zircon, glazed tiles, china clay, Paper industries, paper board, duplex, oil industries, castor, ground nut, soya, oilseeds, plastics industries, rotor molding, reprocessed granule, pvc resin, pvc cable, Pint industries, Pigments, emulsions, aluminum paste, varnish, solvents, et cetera, Chemicals industries, dyes, intermediates, paints, pigments, pesticides, Pharmaceutical industries shifting, tablet de dusting, granule grading, metal industries, Ferro alloys, C. I Powder, foundries, and many more...

Model	Vibro Screen Machine's Diameter mm	Vibro Screen Machine's Diameter Inch	Motor HP
JAS 600	600	24"	0.5
JAS 750	750	30"	0.5
JAS 900	900	36"	1.0
JAS 1200	1200	48"	2.0
JAS 1500	1500	60"	3.0
JAS 1800	1800	72"	5.0

### Standard accessories of Gyro Screen

- Per deck one screen.
- Suitable vibratory electric motor.
- 3 meter cable & 3 pin top
- Dust Cover For Vibro Screen (This accessory is must for dust free screening. It is conical cover with an inlet hole in center for feeding material and as inspection window to see the screening process on the mesh. Dust cover is clamped on the topmost deck with the help of 'V' grooved and 'C' clamp and can be removed easily if not required.)

### Extra accessories of Vibro Screen

- Extra Screens
- Starters, main switch, ampere meter, capacitor for Three Phase Electric Motor.
- Suitable miniature circuit breaker as per IS: 8828 with 3 pin top as per IS: 1293 for single phase electric motors.
- Anti Vibrating Mount
- Feeder Hopper ( This device helps you to ensure continuous and steady feed to the machine. Very useful where feed material is to be manually dumped from bags.)
- Mesh Fixing Fixture (A useful accessory in case where mesh is to be tied frequently due to high wear and tear from abrasive or heavy nature of material. It is still advisable to keep a spare screen ring if the mesh change over is to be done fast.)
- Ball Tray / Ring Tray (This is useful to achieve non clog screening. A tray having rubber /PP balls or rings is mounted underneath the fine mesh screen. The ball / ring get continuous vibrations from machine and hence they jump and hit the fine mesh from below. This makes particles trapped in the mesh holes to fall down and thereby keep mesh opening as clear as possible.)



## Specifications of Vibro Screen (Gyro screen)

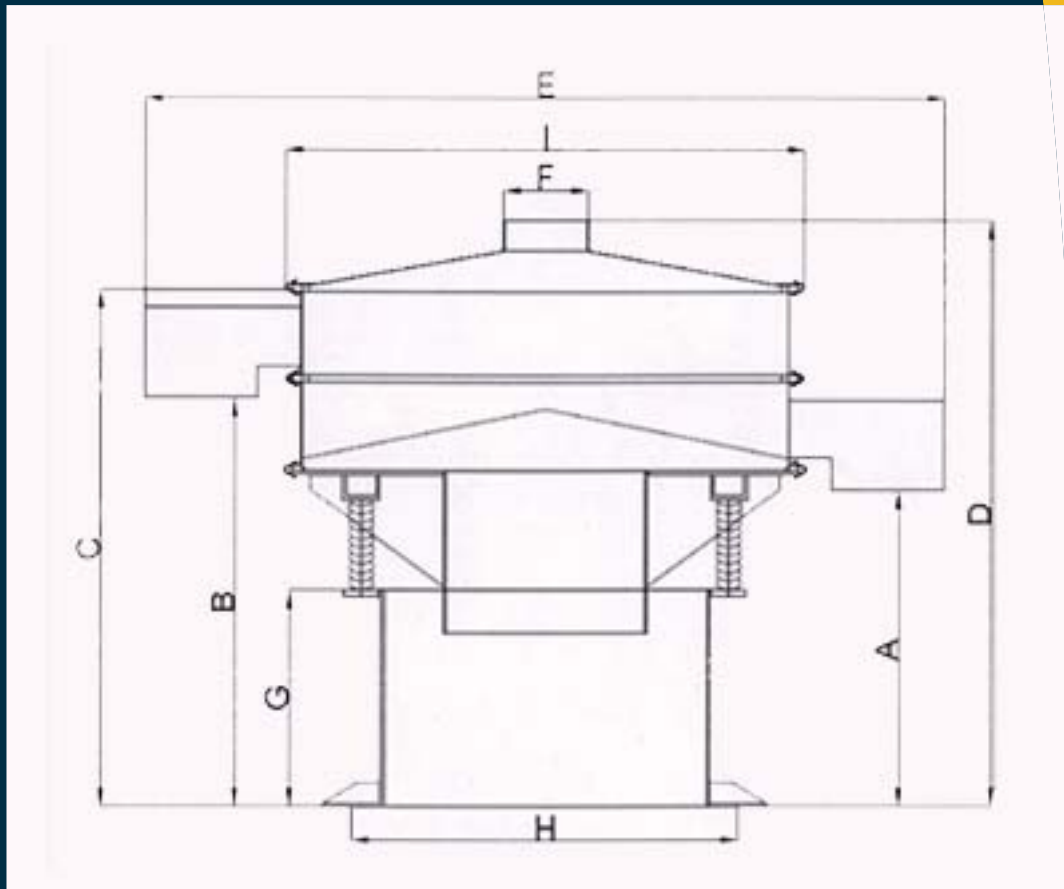

Model NO	A	B	C	D	E	F	G	H	I
JAS 600	400	530	640	780	880	150	275	450-530	625
JAS 750	400	580	730	825	1110	150	300	530-610	780
JAS 900	525	720	830	880	1300	150	350	560-640	925
JAS 1200	600	790	945	1105	1780	250	400	825-925	1240
JAS 1500	625	850	1030	1220	2080	300	450	1020-1120	1535
JAS 1800	650	885	1065	1250	2480	300	450	1200-1300	1835